



OWNERS MANUAL

# BUILT IN & FREE STANDING

WINE FRIDGE  
GC90SBLK, GC42SBLK

BEVERAGE FRIDGE  
GC42BCBLK

# GRAND CRU®



@GrandCruWineFridges



NEED HELP? CALL

1300 935 683

AUSTRALIA

0800 880 100

NEW ZEALAND

[www.grandcruwinefridges.com.au](http://www.grandcruwinefridges.com.au)



## CONTENTS



GC42SBLK



GC90SBLK



GC42BCBLK

#### **4 IMPORTANT SAFETY INFORMATION**

- 4 FOR YOUR SAFETY
- 5 APPLIANCE USE
- 5 ELECTRICAL CONNECTION
- 5 BEFORE OPERATION

#### **6 FRIDGE STRUCTURE**

- 6 WINE FRIDGE GC42SBLK
- 7 BEVERAGE FRIDGE GC42BCBLK
- 7 WINE FRIDGE GC90SBLK

#### **8 CONTROL PANEL**

- 8 OPERATING THE CONTROL PANEL
- 8 SETTING THE TEMPERATURE

#### **9 OPERATION & CARE**

- 9 WORKING CLIMATE
- 9 ENERGY SAVING TIPS
- 9 RECOMMENDED TEMPERATURES
- 9 CLEANING

#### **10 TROUBLESHOOTING**

#### **11 WARRANTY, SERVICE AND SUPPORT**

#### **12 STORING AND STACKING**

#### **13 FREQUENTLY ASKED QUESTIONS**

#### **17 WINE STORAGE GUIDE**

#### **19 WINE TEMPERATURE SERVING GUIDE**

## IMPORTANT SAFETY INFORMATION

### BUILT IN & FREE STANDING

WINE FRIDGE  
GC90SBLK, GC42SBLK

BEVERAGE FRIDGE  
GC42BCBLK



This manual contains important information including safety and installation instructions of the appliances. Please read it carefully before use and follow all safety information & instructions. It is recommended to keep this manual for easy reference so that you can be familiar with the operation of the appliance.

### DO NOT TURN ON FOR AT LEAST 24 HOURS AFTER DELIVERY



Let the appliance stand upright for approximately 24 hours before connecting it to the power source, which helps to reduce the possibility of a cooling-system malfunction from handling during transportation.

### FOR YOUR SAFETY

- To prevent injury or damage to the unit, the appliance should be unpacked and set up by two people.
  - In the event that the appliance is damaged on delivery, contact the supplier immediately before connecting to the mains.
  - To guarantee safe operation, ensure that the appliance is set up and connected as described in these operating instructions.
  - Disconnect the appliance from the mains if any fault occurs pull out the plug.
  - When disconnecting the appliance, pull on the plug, not on the cable.
  - Do not allow naked flames or ignition sources to enter the appliance.
- When transporting and cleaning the appliance, ensure that the refrigerant circuit is not damaged. In the event

- of damage, make sure that there are no ignition sources nearby and keep the room well ventilated.
- Any repairs and work on the appliance should only be carried out by the Grand Cru service department, as unauthorised work could prove highly dangerous for the user. The same applies to changing the mains power cable.
  - Do not stand on the plinth, drawers or doors or use them to support anything else.
  - Persons with restricted physical, sensory or mental capacity or lack of experience and knowledge, should not use this appliance. Children must not be allowed to play with the appliance. Cleaning and user maintenance must not be carried out by children without supervision.
  - Do not store explosives or sprays using combustible propellants such as butane, propane, pentane, etc. in the appliance.

Electrical components might cause leaking gas to ignite. You may identify such sprays by the printed contents or a flame symbol.

- Do not use electrical appliances inside the appliance.
- If you have a lockable appliance, do not keep the key near the appliance or within reach of children.
- The appliance is designed for use in enclosed areas. Do not operate the appliance outdoors or in areas where it is exposed to splash water or damp conditions.
- When transporting or operating the appliance at an altitude of more than 1500m above sea level, the glass pane in the door can break due to the reduction in air pressure.

## APPLIANCE USE

The appliance is suitable solely for storing wine in a domestic environment or similar.

- In staff kitchenettes, bed, and breakfast establishments,
- By guests in cottages, hotels, motels, and other forms of accommodation, in catering and similar services in the wholesale trade.

Use the appliance solely as is customary within a domestic environment. All other types of use are inadmissible. The appliance is not suitable for storing and cooling medicines, blood plasma, laboratory preparations or similar substances and products covered by the 2007/47/EC Medical Devices Directive. Any misuse of the appliance may result in damage to or spoilage of stored goods. Furthermore, the appliance is not suitable for operation in potentially explosive atmosphere.

## ELECTRICAL CONNECTION

- Only operate the appliance with alternating current (AC).
- The permissible voltage and frequency are indicated on the type plate. The position of the type plate is shown in the section entitled Description of the appliance.

- The socket must be properly earthed and protected by a circuit breaker. The tripping current of the CB must be between 10 A and 16 A
- The socket must be easily accessible
- Do not connect the appliance using an extension cable or extension socket
- Do not use stand-alone inverters (conversion of direct current to alternating/ three-phase current) or energy-saving plugs as this would increase a risk of damage to the electronic control system.

## BEFORE OPERATION

- The devices are to be carried diagonally. That means that the person carrying the underside carries the device on its front grid (below the doors) and that when negotiating stairs this person always stands the lower.
- If the device has to be temporarily set down then this it should be stood straight up, and not placed on its side.
- This device cannot be laid down.
- Avoid positioning the appliance in direct sunlight or near cookers, radiators and similar sources of heat.
- Place the device on a firm, dry and plain-level surface. The cabinet should not be exposed to temperatures below freezing point, vibrations, or a wet environment.
- Always install the appliance directly against the wall.
- With the front leveling legs, the cabinet can be leveled so that it stands completely straight, even if there is any unevenness in the floor.



**Important:** After definitive placement of the cooling cabinet it should not be connected to power for the duration of at least **12 hours**, the compressor may be damaged if this instruction is not followed.

# FRIDGE STRUCTURE

## WINE FRIDGE GC42SBLK

### With Display Shelf

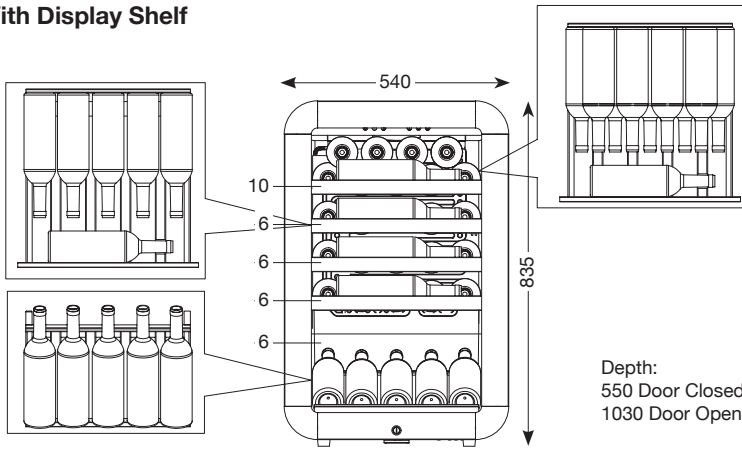

### Without Display Shelf

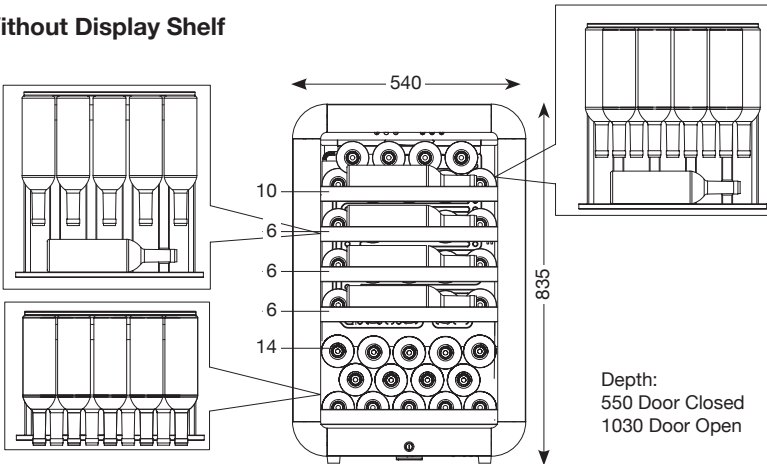

**BEVERAGE FRIDGE GC42BCBLK**

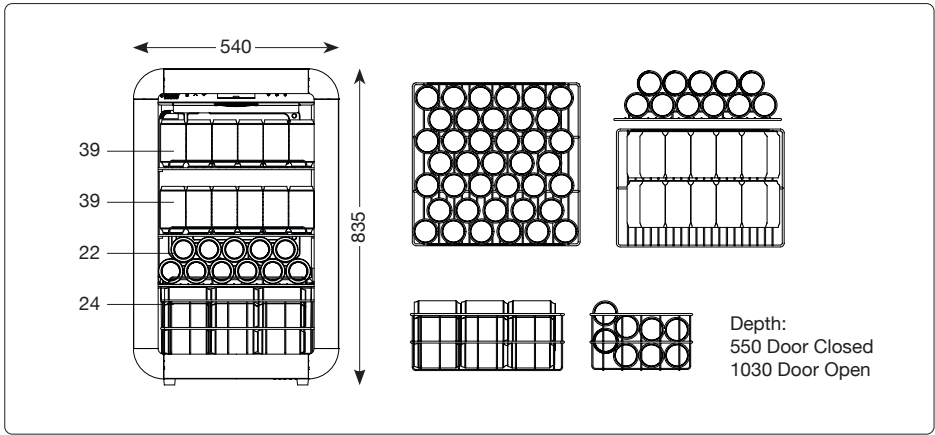

**WINE FRIDGE GC90SBLK**

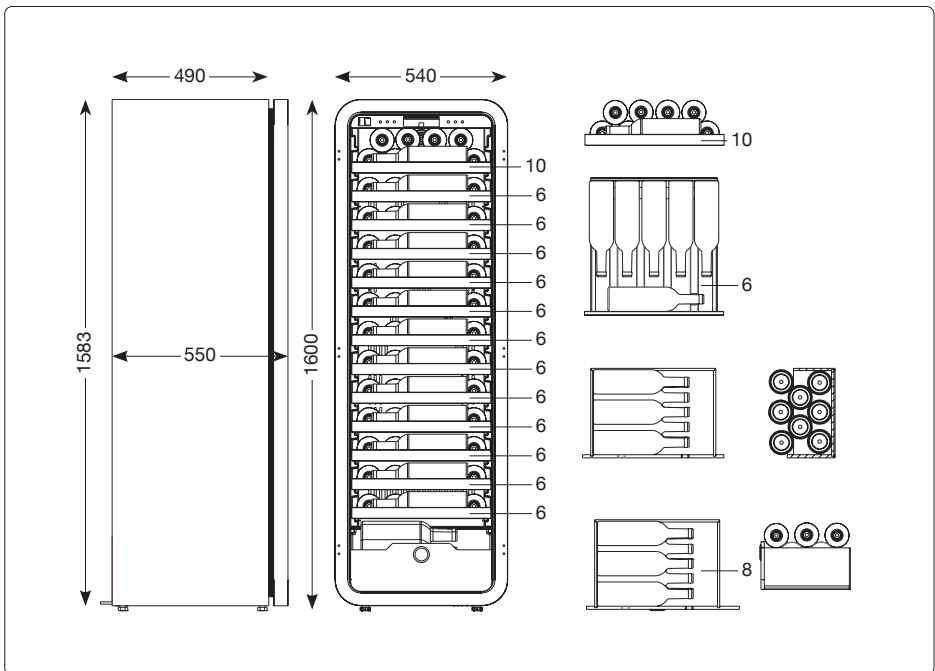

## CONTROL PANEL

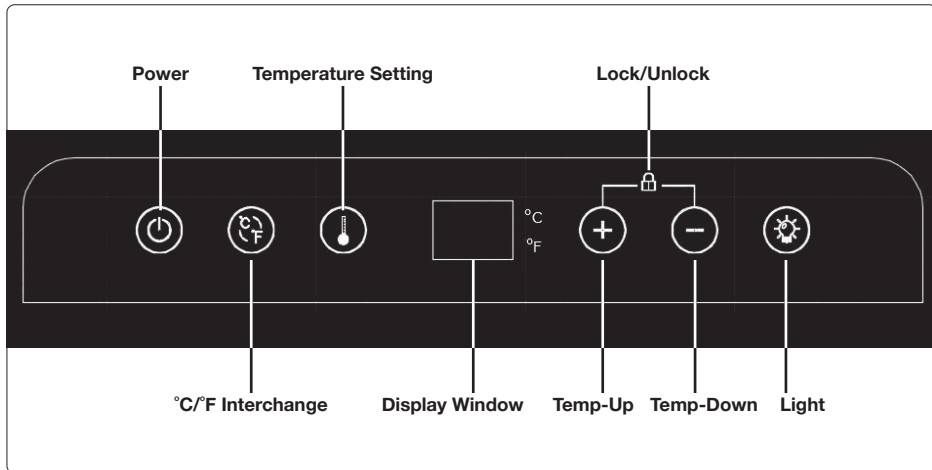

### OPERATING THE CONTROL PANEL

- **Power switch:** After the unit is power on, press for **3 seconds** to turn on or off the unit.
- **°C/°F switch:** Press button to change the temperature display between Celsius and Fahrenheit.
- **Temperature setting button:** Press before adjust temperature. When press it first time, the display flashes and shows the setting temperature. After **5 seconds** it shows the measured interior temperature. Press to increase the setting temperature and press to decrease the setting temperature.
- **Display window:** 2-digit LED display to show setting temperature or actual interior temperature.
- **Light button:** Press to turn on or off. When open door, the light will be switched on automatically.
- **Key lock function:** If there is not any operation with digital control for **3 minutes**, it will be locked automatically. Press and at the same time for **3 seconds** to unlock.

### SETTING THE TEMPERATURE

- You can set the temperature as you desire by pushing the or button. When you push the two buttons for the first time, the LED readout will show the original temperature set at previous time.
- The temperature that you desire to set will increase 1°C if you push the button once, on the contrary the temperature will decrease 1°C if you push the button once.
- To view the “set” temperature. (anytime) press and hold the corresponding button for approximately 5 seconds, the “set” temperature will temporarily “flash” in the LED display for 5 seconds.

## OPERATION & CARE

### WORKING CLIMATE

The appliance is designed for operating from SN to T climate (see below climate class chart). It is recommended to maintain the ambient around 22-25°C which helps the appliance working with low power consumption.

Climate Class	Ambient Temperature
SN = Subnormal	10°C -32°C (50°F-90°F)
N = Normal	16°C -32°C (61°F-90°F)
ST =Subtropical	16°C -38°C (60°F-100°F)
T = Tropical	16°C -43°C (60°F-109°F)
SN-ST = Subnormal – Subtropical	10°C -38°C (50°F-100°F)
SN-T = Subnormal -Tropical	10°C -43°C (50°F-109°F)

If the ambient temperature is above or below the designed climate range, the performance of the unit may be affected. For example, the appliance operating in extreme cold or hot conditions may cause interior temperatures to fluctuate, and the temperature set 5-20°C may not be reached sometimes.

### ENERGY SAVING TIPS

- Always ensure good ventilation. Do not cover ventilation openings or grille.
- Always keep fan slits clear.
- Avoid positioning the appliance in direct sunlight or near cookers, radiators, or similar sources of heat.

- The energy consumption depends on the installation conditions, e.g. the ambient temperature.
- Keep the time the appliance is open to a minimum.

### RECOMMENDED TEMPERATURES

Wine Type	Recommended Temperature
Red	14-18°C (59°F-64°F)
White	6-14°C (48°F-57°F)
Rose	6-12°C (50°F-52°F)
Sparkling	4-10°C (41°F-46°F)

For further information see the "WINE TEMPERATURE SERVING GUIDE" on page 19.

### CLEANING

- Before cleaning always switch off the appliance. Pull out the mains plug or switch off.
- Clean the inside and outer walls with lukewarm water and a little detergent. Do not use abrasive or acid cleaners or chemical solvents
- Use a glass cleaner to clean the glass surfaces and a commercially available stainless-steel cleaning agent for the stainless-steel surfaces
- Do not use steam cleaners because of the risk of injury and damage.
- Ensure that no cleaning water penetrates the electrical components or ventilation grille. Do not damage or remove the type plate on the backside of the appliance. It is very important for servicing purposes.

## TROUBLESHOOTING

If you feel the appliance is out of order, follow these instructions to try to see if you can solve the problem simply by yourself before calling for service.

Problem	Problem Possible Cause / Measure
E1, E2, E3, 88.88, HH or LL appears in the display	The appliance has suffered a fault. Contact the customer service department. You may be able to rectify the following faults by checking the possible causes yourself.
Appliance does not function	<ul style="list-style-type: none"> <li>• Is the appliance on?</li> <li>• Is the plug correctly fitted to the mains socket?</li> <li>• Is the fuse intact?</li> </ul>
When inserting the mains plug, the refrigeration unit does not switch on, but a value is shown in the temperature display	Demo mode is activated. Please contact the customer service department
Loud running noise	<ul style="list-style-type: none"> <li>• Is the appliance set up firmly on the floor?</li> <li>• Does the appliance cause nearby items of furniture or objects to vibrate? Please note that noises caused by the refrigerant circuit cannot be avoided</li> </ul>
The temperature is not low enough	<ul style="list-style-type: none"> <li>• Is the temperature setting correct (see "Setting the temperature")? Does the separately installed thermometer show the correct reading? Is the ventilation system working properly?</li> <li>• Is the appliance set up too close to a heat source</li> </ul>

## **WARRANTY, SERVICE AND SUPPORT**

---

Thank you for purchasing a Grand Cru Wine Fridge from Home Icon International Pty Ltd. Home Icon provides a 5-year warranty on the Grand Cru range of Wine Fridges.

---

### **WARRANTY REGISTRATION**

---

Register your wine fridge now for warranty, and allow us to provide you with the best possible after sales service:

1. Go to our website: Australia ..... [www.grandcruwinefridges.com.au](http://www.grandcruwinefridges.com.au)  
New Zealand ..... [www.grandcruwinefridges.co.nz](http://www.grandcruwinefridges.co.nz)
2. Click on the **'Support'** tab across the top
3. Select **'Warranty Registration'** and fill out the details as required

This warranty does not cover the following:

- Any damages caused from improper use or not used in accordance with the instruction manuals.
- Damage caused by connecting your product to the wrong power source/supply.
- Incorrect installation or modifications made during installation or use of the product.
- Removing screws or otherwise opening the outer case will void the warranty.
- Any damages resulting from poor handling or moving of the product, misuse, fire or water damage etc.
- Failure to maintain the product as per the Instruction Manual.
- Problems caused by incorrect or inadequate venting of the product.

---

### **SERVICE AND SUPPORT**

---

Should an instance arrive where you require assistance, contact our support team:

1. Go to our website: Australia ..... [www.grandcruwinefridges.com.au](http://www.grandcruwinefridges.com.au)  
New Zealand ..... [www.grandcruwinefridges.co.nz](http://www.grandcruwinefridges.co.nz)
2. Click on the **'Support'** tab across the top
3. Select the **'Request a Service'** option and fill out the details as required



#### **NEED HELP? CALL**

**1300 935 683**    **0800 880 100**  
AUSTRALIA                      NEW ZEALAND

## STORING AND STACKING

### DIFFERENT SHAPES AND SIZES

This brochure makes reference to the 'standard Bordeaux style bottle' when specifying capacity. However, wine producers use a huge range of different bottle shapes and sizes. Bottle shape variety should be considered when selecting the appropriate Grand Cru cabinet in which to house your precious collection, since shelf height and adjustability varies across the product range. Please also be aware that some bottles will not fit opposite each other on the same shelf and this may affect capacity. You may need to lay the bottles opposite more suitably shaped bottles. Ideally, bottles should lie with their necks comfortably interlocking.

### STACKING FOR AGEING

When filling your cabinet, we suggest stacking the bottles you wish to cellar and mature at the back of the shelves, and the wines you wish to consume in the short term at the front.

### STACKING FOR ACCESSIBILITY

When stacking bottles, it is practical to keep bottles from the same case together. See diagrams below, in which bottles from the same case are represented by the same colours. Vertically stacking same-case bottles enables safe and easy access to all your different wines.

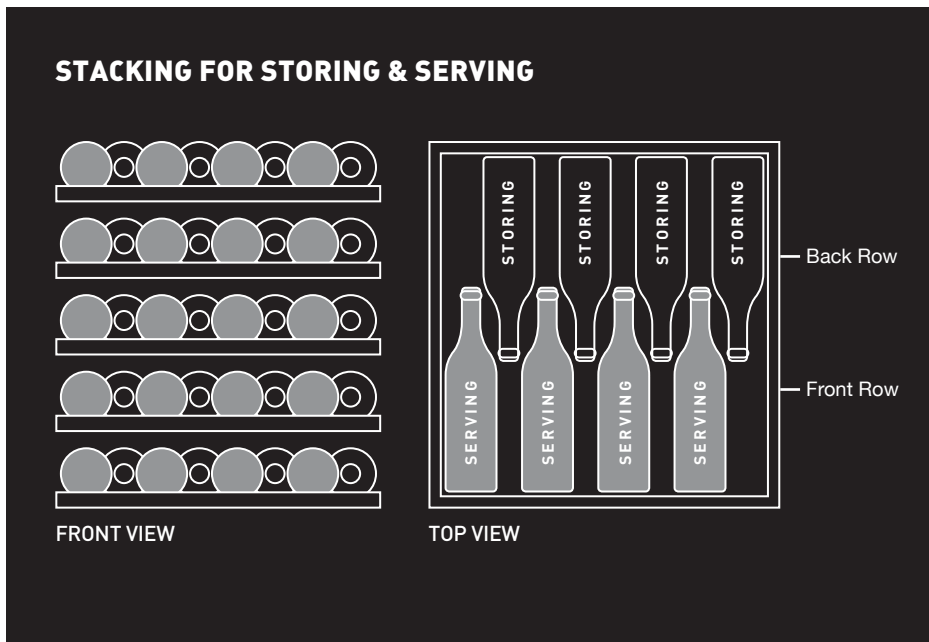

## FREQUENTLY ASKED QUESTIONS



### CHOOSING THE RIGHT WINE FRIDGE

#### **To keep my wines ready to serve at the perfect drinking temperatures?**

Choose any Dual-Zone Grand Cru wine fridge, and keep in mind that most whites are generally best served at 6-8 deg C, and most reds at 16-18 deg C. With a Dual-Zone cabinet, you can fine-tune the serving temperatures of different styles of wine: You can set the temperature to suit your needs.

#### **To store my wines in the ideal cellaring conditions so they can mature?**

Choose any Grand Cru Wine fridge, and make sure you set it at 12-14 deg C as this is the proper temperature for cellaring and medium/long term storage for all wines: reds, whites, roses and champagne.

#### **To cellar only white wines or only red wines?**

All wines cellar at the same temperature (12-14 deg C), so any Single-Zone fridge set between 12-14 deg C is ideal for white wine and/or red wine storage. When set

within this temperature range, Single-Zone fridges will also keep humidity levels above 55% (which is important to maintain the integrity of the cork). Having said that, any dual zone can also be kept at the same temperature and humidity levels throughout the whole unit.

#### **To cellar both red and white wines?**

All wines — Whites, Reds, Champagnes — cellar at the same temperature (12-14 deg C), so any Grand Cru fridge set between 12-14 deg C is ideal for white wine and/or red wine storage. Set within this temperature range, Grand Cru wine fridges will also keep humidity levels above 55% (which is important to maintain the integrity of the cork).

#### **My wine is purely for investment: which wine fridge will suit me best?**

For (investment) wine to appreciate in value, the discerning purchaser will want a wine fridge that is designed for cellaring at the perfect temperature so any of the Grand Cru units will suit that purpose – it just becomes more of a question of the size of unit needed.

---

## **WINE TEMPERATURE**

---

### **At what temperature should I be cellaring my wines?**

The recommended cellaring temperature is between 12 and 14 degrees Celsius. Whichever temperature you choose, the key is to remember that the temperature must be constant.

### **What should the humidity levels be in my wine cabinet?**

The humidity in a wine cabinet should be over 55% so that corks don't dry out and shrink: humidity levels below 55% can lead to your wines spoiling because of oxidation. All Grand Cru wine fridges are designed to maintain humidity levels above 55% (when set at 12-14 deg C).

### **Do I need humidity control when cellaring my wines?**

YES, humidity is essential to ensure that the corks do not dry out. If that happens, they shrink and air can get into the wine. If air gets into the wine it will cause oxidation, generating an odorous smell.

### **How long can I keep my wines in a Dual -Zone wine fridge?**

As long as the temperature is correct, there is no limit to how long your wine can be stored in there.

### **Can I use my wine fridge for beer and food?**

No, wine fridges are not normal fridges. The temperature does not go low enough to keep food fresh and are not cold enough for the serving of beer. The Grand Cru GC46BC Beverage Centre is designed for beers (or white wines at drinking temperature), as they can cool beverages down to 2 deg C, and have metallic racks on which to stand beer bottles up. However, they are not suitable for food storage.

### **I have a Dual-Zone wine cabinet. Can I use one compartment for the serving of my white wines and the bottom compartment for cellaring my wines?**

YES. Just set the top compartment temperature to between 6\*-8\* and the bottom section to a temperature range of 12\*-14\*.

---

## **TECHNICAL & INSTALLATION**

---

### **What is the difference between Dual-Zone cabinets and Single-Zone wine cabinets?**

Dual -Zone wine fridges are designed for keeping and serving red and white wines at the perfect drinking temperatures. Single-Zone wine cabinets are designed for cellaring all wines (reds, whites or sparkling) at the proper temperature (12-14 deg C).

### **Does my cabinet require ventilation and can it be built-in under bench?**

Some of the Grand Cru range are not suitable for built -in installation, so please consider this before purchasing. The following Grand Cru wine fridges are suitable for built in installation: GC46, GC100, GC166, GC183 & GC194.

---

## **TROUBLE SHOOTING**

---

### **My unit is making a lot of noise**

If your wine fridge sounds noisy, it may be: 1) due to incorrect stacking of bottles and/ or the fridge is not completely level, so please empty the unit, check the levelling and then reload, 2) because ventilation requirements have not been considered, and so the unit is over-heating —refer to the manual or call Grand Cru for further help.

### **There is water coming out of the back of my cabinet.**

The door has been left open to some degree. Please wipe out the unit and ensure the door is shut.

**There is water on the inside back wall of my cabinet**

This is a perfectly normal occurrence and needed to maintain the correct humidity in the wine fridge. Just keep your bottles away from the wall so you do not block the water flow, an essential part of the cellaring climate.

**My bottles are wet**

If they are in contact with the back wall of the cabinet, they will have some condensation on them so please make sure you keep a finger's distance between the bottom of the bottle and the wall when you load. If not, please keep in mind that it is normal that condensation appears on the bottles after you open the door, and that high humidity is essential in cellaring your wine properly.

**There is a +/- 2 deg temperature swing on the digital readout**

Yes, this is normal. It is the variance in the air temperature that triggers the thermostat and the compressor. The small temperature fluctuations occur in the air around the bottles, not in the wine itself.

**There is condensation on the outer surface of the glass door of my wine cabinet**

This indicates excessive humidity in the environment.

**What happens if there is a power outage?**

The units are very well insulated and can maintain the temperature for hours before there is any change in the temperature itself. We don't advise opening the doors during the outage. Once the power is restored, electronically-controlled cabinets can revert to factory settings, so reset as necessary.

---

**SHIPPING & DELIVERY**

---

**What happens if my home/property is damaged?**

While this scenario is extremely rare, it can occur. If anything at your home/property is damaged by the carrier, contact Customer Support immediately! We will make the initial arrangements with the carrier to get compensation to you in a quick and timely fashion. As always, notate the BOL of what was damaged before you sign!

Note: Grand Cru cannot give direct compensation for damages that occur to your home/property before and/or after the fact. These actions have to be negotiated through you and the carrier, but as our customer we will give you all the necessary information and assistance needed to make sure you have a timely and satisfactory resolution to the matter.

**I signed for my wine cellar as delivered for in satisfactory condition, but I discovered damage later on. What do I do?**

If this occurs, please contact Customer Support immediately! There is a window of 48 hours where you would still be entitled to a replacement and/or compensation. After the window lapses, we cannot provide a replacement or compensation as the wine cellar is officially signed off "AS IS"

**I am receiving or I have received delivery and certain services are not being rendered or were not rendered. What do I do?**

Contact Customer Support so we can look into the matter directly with the carrier. We may be able to have the services rendered and/or provide compensation for the inconvenience. Note: Make sure you are informed of what services that are and are not included in your delivery. Refer to this information packet or you can discuss this at the time of purchase with your Home Icon Customer Representative before delivery.

**Does the carrier install/assemble any components (such as shelving) at the time of delivery?**

No. We cannot nor do we authorise the carrier to install shelving or assemble any part of the wine fridge. This is always the responsibility of the client regardless of what services are being rendered. If you require a white glove unpacking service, please contact Customer Support to find out more as this feature incurs a fee.

We hope that this has been informative and insightful information that will help you not only on your purchase, but as well as the delivery process. Should you have any further questions in regards to this information and/or should you have questions that are not included in this information packet please do not hesitate to contact us.

---

**CUSTOMER SUPPORT**

---

**AUSTRALIA** – Phone: 1300 935 683

Email: [info@homeicon.com.au](mailto:info@homeicon.com.au)

**NEW ZEALAND** – Phone: 0800 880 100

Email: [sales@grandcruwinefridges.co.nz](mailto:sales@grandcruwinefridges.co.nz)

**NEED HELP? CALL****1300 935 683**

AUSTRALIA

**0800 880 100**

NEW ZEALAND

## WINE STORAGE GUIDE

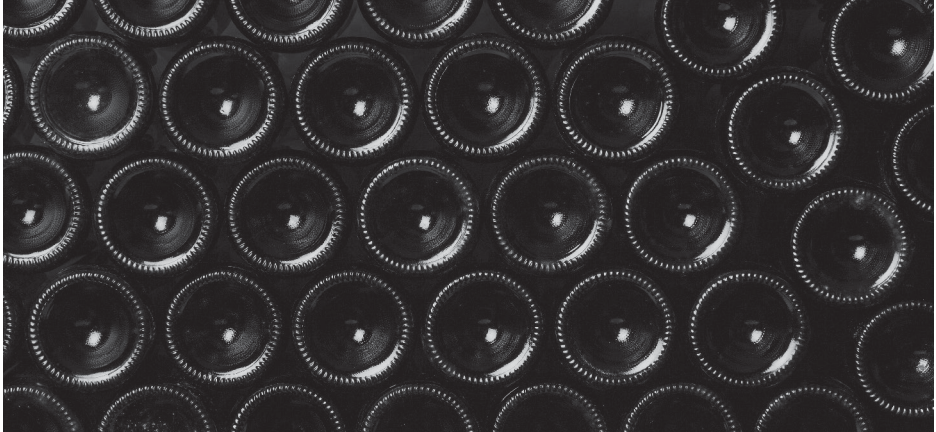

### SOME HELPFUL ADVICE

Have you bought some nice wine that you are planning keep for a special occasion or maybe you wish to start your own wine collection. What are the best tips for successfully storing your wine?

Firstly, it's useful to remember that only a small percentage of fine wines on the market benefit from long-term aging. Most wines are best enjoyed within a few years of release. If you're looking to buy wines to mature, you should really consider investing in a proper wine fridge or an external wine storage solution, but more about that later.

For everyone else, however, following a few simple guidelines should keep your wines safe until you're ready to drink them.

#### 1. KEEP IT COOL

Heat is enemy number one for wine. Temperatures higher than 21°C will age a wine more quickly than is usually desirable. And if it gets too much hotter, your wine may get "cooked," resulting in flat aromas and flavours. The ideal temperature range

is between 7°C and 18°C (and 14°C is often cited as close to perfect), though this isn't an exact science. Don't worry too much if your storage runs a couple degrees warmer, as long as you're opening the bottles within a few years from their release.

#### 2. BUT NOT COLD

Keeping wines in your household refrigerator is fine for a couple months, but it's not a good bet for the longer term. The average fridge temp sits between 3 - 4°C to safely store perishable foods, and the lack of moisture (humidity) could eventually dry out corks, which might allow air to seep into the bottles and damage the wine. Keeping wine in a fridge for a longer time will also slow down the aging process which is not ideal.

#### 3. CONSISTENCY IS THE KEY

More important than worrying about achieving a perfect 12°C is avoiding the landmines of rapid, extreme or frequent temperature variations. Temperature variation is likely to be more critical for older wines where the seal of the cork is less tight (corks lose some elasticity

with age). The problem with temperature variations is that the volume of the wine expands as temperature rises, decreasing the ullage volume, and then contracts as temperature falls, increasing the ullage volume. If the closure is providing a completely airtight seal then this is of relatively little consequence. Aim for consistency, but don't get paranoid about minor temperature fluctuations; wines may see worse in transit from the winery to the store. (Even if heat has caused wine to seep out past the cork, that doesn't always mean the wine is ruined. There's no way to know until you open it—it could still be superb).

#### **4. TURN OFF THE LIGHTS**

Light, especially sunlight, can pose a potential problem for long-term storage. The sun's UV rays can degrade and prematurely age wine. One of the reasons why vintners use coloured glass bottles? They're like sunglasses for wine. Light from household bulbs probably won't damage the wine itself, but can fade your labels in the long run.

#### **5. HUMIDITY IS IMPORTANT BUT NOT CRITICAL**

Conventional wisdom says that wines should be stored at an ideal humidity level of 70 percent. The theory goes that dry air will dry out the corks, which would let air into the bottle and spoil the wine. Yes, this does happen, but unless you live in a very dry desert or arctic like climate, it probably won't happen to you. Anywhere between 50 percent and 80 percent humidity is considered safe, and placing a tray or saucerpan of water in your storage area can improve conditions. Conversely, extremely damp conditions can promote mould. This won't affect a properly sealed wine, but can damage the labels. A dehumidifier can fix that.

#### **6. FLAT OR STANDING – STORING OR ON SHOW**

Traditionally, bottles have been stored on their sides in order to keep the liquid up against the cork, which theoretically should keep the cork from drying out. If you're planning on drinking these bottles in the near-term, or if the bottles have alternative closures (screw caps or synthetic corks), this is not necessary.

#### **7. LIMIT THE MOVEMENT**

There are theories that vibration could damage wine in the long term by speeding up the chemical reactions in the liquid. Some serious collectors worry about even the subtle vibrations caused by electronic and other appliances, though there's little evidence supporting the impacts of this. Significant vibrations could possibly disturb the sediment in older wines and keep them from settling, potentially making them unpleasantly gritty.

---

#### **WHERE SHOULD I STORE MY WINE?**

---

If you do not have a cool, not-too-damp basement or underground garage that can double as a fridge, you can improvise with some simple wine racks in a safe place. Rule out your kitchen or laundry, where hot temperatures could affect your wines, and look for a location that is generally less effected by climate control systems and not directly in line with sun light pouring in from a window. Perhaps there is a little-used closet or other vacant storage area that could be repurposed for storing wine?

## WINE TEMPERATURE SERVING GUIDE



### HOW TO SERVE WINE

When it comes to serving your favourite bottle of wine at the correct temperature, ideally it should be just right. Too hot and the wine's alcohol will be emphasized, leaving it flat and flabby. Too cold and the aromas and flavours will be muted and, for reds, the tannins may seem harsh and astringent. The old adage of serving white wines chilled and red wines at room temperature is a useful starting point, although not nearly detailed enough.

The reason we try to serve wine at their correct temperatures is because the temperature can dramatically impact the way a wine smells and tastes. By serving the wine at its ideal temperature, we ensure we will always get the best experience and enjoyment from our favourite bottle.

For those like myself who wish to be even more specific, I have included below some more detailed serving temperature recommendations for Australia's most popular wine varieties.

### NON-VINTAGE CHAMPAGNE/SPARKING WINE AND ICE WINE – ICE COLD, 4-6°

I like to put my bubbly in the freezer about an hour before I pop it – but don't forget about it or you'll have an explosion. If you're short on time, you can also place the bottle in an ice bucket for 30 minutes and have similar results. The ice cold temperature will keep the bubbles fine rather than foamy. After you open the bottle and pour the first glasses, you should place the open bottle on ice until the entire bottle is finished.

### LIGHTER BODIED WHITE WINE, SWEETER ROSÉ, VINTAGE CHAMPAGNE AND DESSERT – COLD, 6-10°

The best way to get lighter bodied white wine and sweeter rose cold is to place it in the fridge immediately after buying it; however, if you buy the wine already chilled the same day you want to drink it, either leave it in the fridge for several hours, or you can place it in the freezer for about 30 minutes. After you open the bottle and pour the first glasses, you should place the open bottle on ice until the entire bottle is finished.

**FULL BODIED WHITE WINE AND DRY ROSÉ – COOL, 10-14°**

The best way to get full bodied white wine cool is to place it in the fridge or preferably a wine fridge immediately after buying it. I suggest taking the wine out of the fridge 30 minutes prior to serving and after opening the bottle and pouring everyone their first glass, I prefer not to place it on ice, but instead let the bottle sweat on the table, as the wine's aromas and character changes slightly as the temperature rises.

**LIGHTER BODIED RED WINE – COOLED, 12-16°**

The most common misconception with lighter bodied red wine is that it is ideal to serve it at room temperature (see below), when in fact serving it cool is the best way to enjoy it. To cool lighter red down to its proper serving temperature, either place it in the fridge an hour before serving or preferably invest in a good quality wine fridge and serve immediately at the right temperature. After opening and either decanting or pouring the first glasses, just as with full bodied white I like leaving the wine out on the table to slowly warm.

**FULL BODIED RED WINE – ROOM TEMPERATURE, 16-18°**

Depending on the time of year, room temperature in Australia sits somewhere between 20°C and 25°C which is not the ideal serving temperature. Red wine served too warm will lose all its finesse and freshness to an overpowering sensation of alcohol. To cool full bodied red down to its ideal serving temperature, I like to place it in the fridge 20 minutes before serving or preferably invest in a good quality wine fridge and just take it out 15 minutes prior to serving. After opening and either decanting or pouring the first glasses, leave the wine out on the table.

**POCKET GUIDE**

---

**19° - VINTAGE PORT**

---

**16° - 18° SHIRAZ, DURIF, CABERNET SAUVIGNON**

---

**14° - 16° PINOT NOIR, GSM, SANGIOVESE CABERNET MERLOT, GRENACHE, TAWNY PORT**

---

**12° - 14° CHARDONANAY, MERLOT, GAMAY**

---

**10° - 12° DRY ROSE, SEMILLON, VIOGNIER, MARSANNE, SAUTERNES**

---

**8° - 10° SPARKLING RED, CHENIN BLANC, REISLING, VERDELHO, SEMILLON SAUVIGNON BLANC, VINTAGE CHAMPAGNE**

---

**6° - 8° SAUVIGNON BLANC, SWEET ROSE, PINOT GRIGIO, PINOT GRIS, DESSERT WINES**

---

**4° - 6° NON-VINTAGE CHAMPAGNE, SPARKLING WHITE, ICE WINES**

---

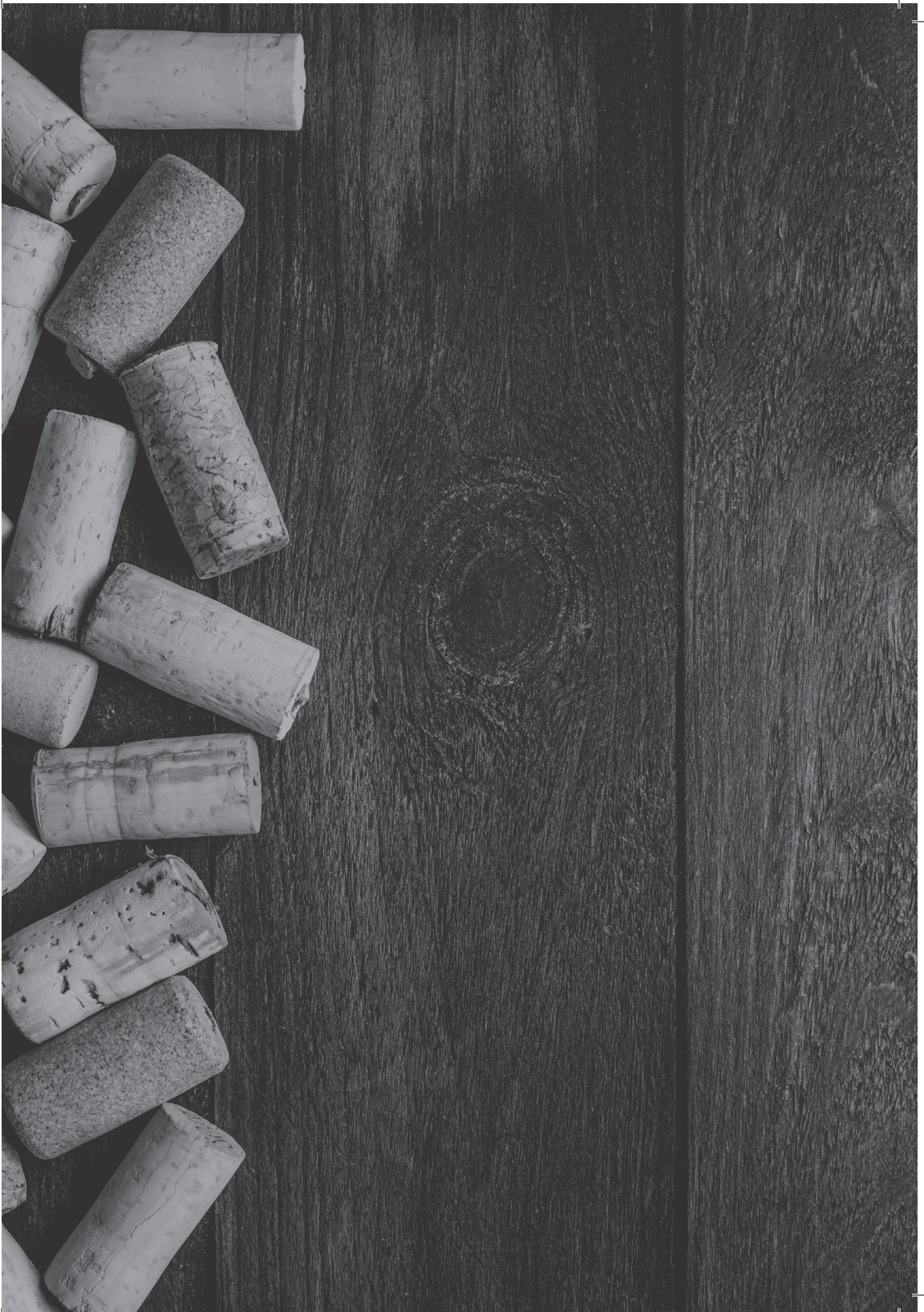



Your wine deserves an exceptional wine fridge.

**GRAND CRU®**



AUSTRALIA  
1300 935 683

[www.grandcruwinefridges.com.au](http://www.grandcruwinefridges.com.au)

Email: [info@homeicon.com.au](mailto:info@homeicon.com.au)



NEW ZEALAND  
0800 880 100

[www.grandcruwinefridges.co.nz](http://www.grandcruwinefridges.co.nz)

Email: [sales@grandcruwinefridges.co.nz](mailto:sales@grandcruwinefridges.co.nz)